

MYERS® ME4 Series

Cast Iron Submersible Effluent Pumps

SPECIFICATIONS

Applications	Septic Tank Effluent Removal, Sump Drainage, and Circulation	
Capacities	62 GPM	235 LPM
Shut-off head	32'	9.8 m
Operation:		
Tethered: On	14"	355.6 mm
Off	5"	127.0 mm
Solids handling	1/2" spherical capability	12.7 mm
Intermittent liquid temp	130°F	55°C
Motor	4/10 HP, 1550 RPM, 115 Volt, 60 Hz. Class B insulation. Oil-filled shaded pole containing built-in thermal overload protection with automatic reset.	
Electrical data	115 V, 60 Hz, single phase	
Acceptable pH range	6-8	
Shaft seal	Mechanical carbon/ceramic	
Motor housing	Cast iron	
Upper volute case	Cast iron	
Lower volute case	Thermoplastic	
Impeller	Thermoplastic Vortex	
Power cord	10' or 20' water resistant 16-3 gauge, type SJTW-A/ SJTW with integrally grounded 3-prong plug.	
Discharge, NPT	1-1/2"	38 mm
Min. sump diameter:		
Simplex	18"	457 mm
Duplex	30"	762 mm



3 YEAR
WARRANTY



FEATURES

- Construction – Heavy-duty cast iron motor housing and upper volute. Corrosion-resistant composite base ideal for effluent applications.
- Bearings and Mechanical Seal – Permanently lubricated for long life.
- Cord Seal – Prevents oil loss from and protection for motor if cord is damaged.
- Overload Protection – Built-in thermal overload with automatic reset.
- Intake – Built-in suction screen.

ORDERING INFORMATION

Catalog Number	HP	Maximum Load Amps	Volts	Phase/Cycles	Cord Length	Mechanical Switch Type	Switch Setting	
							On	Off
ME40110M	4/10	12.5	115	1/60	10'	Manual	-	-
ME40110T						Tethered	14"	5"
ME40120M					20'	Manual	-	-
ME40120T						Tethered	14"	5"

Noryl® is a registered trademark of General Electric Co. Specifications are subject to change without notice.

MYERS® ME4 Series

Cast Iron Submersible Effluent Pumps

OUTLINE DIMENSIONS

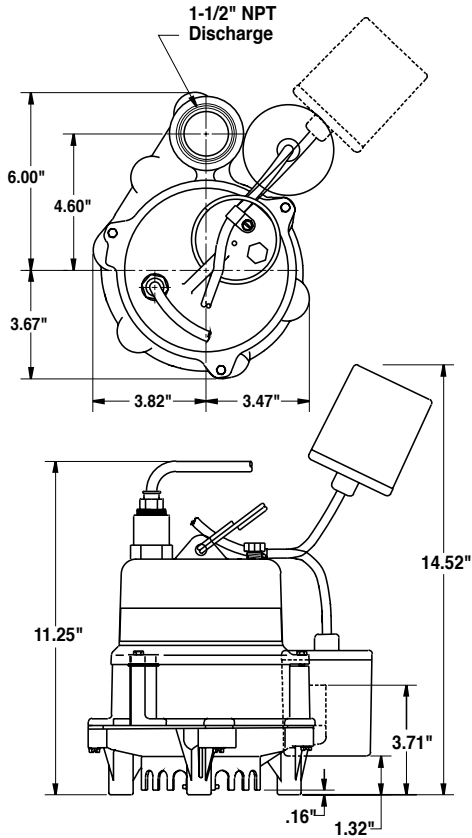

Dimensions (in inches) are for estimating purposes only.

PUMP PERFORMANCE

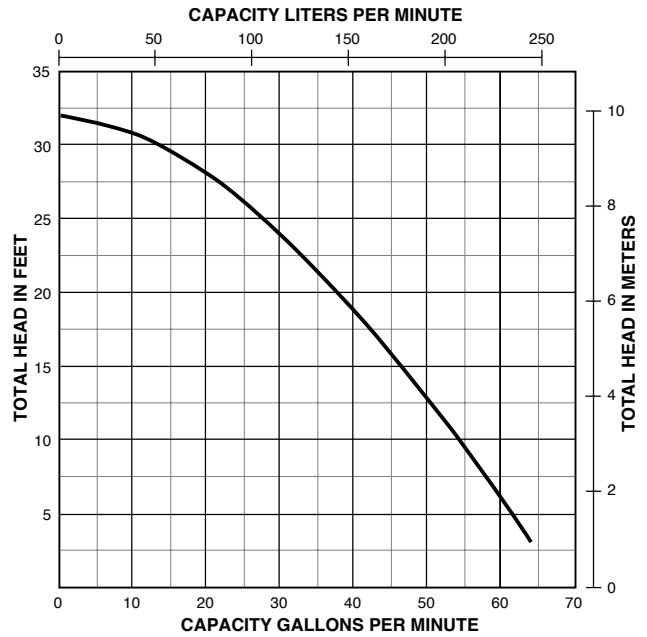

USA
293 WRIGHT STREET, DELAVAN, WI 53115 WWW.FEMYERS.COM
PH: 888-987-8677 ORDERS FAX: 800-426-9446

CANADA
490 PINEBUSH ROAD, UNIT 4, CAMBRIDGE, ONTARIO, N1T 0A5
PH: 800-363-7867 FAX: 888-606-5484

Because we are continuously improving our products and services, Pentair reserves the right to change specifications without prior notice.